

**INSTALLATION
OPERATION
MAINTENANCE
MANUAL**

DX DRAINBACK



**Alternate Energy Technologies
PO Box 61326
Jacksonville, FL 32236
904-781-8305**

CONTENTS

Introduction	1
Basic Tools and Materials	1
1. Collector Location	2
2. Collector Orientation	2
3. Collector Dimensions	3
4. Mounting Hardware	4
5. Mounting Hardware Spacing	7
6. Pitch Pan	7
7. Array Mounting	8
8. Collector Piping	9
9. Collector Piping Detail	9
10. Sensor Mounting at Collector	10
11. Piping Through Roof	10
12. Storage Tank Placement	10
13. Sensor Mounting at Storage Tank	11
14. Drainback DX Fluid Handling System	11
15. Drainback DX Differential Temperature Controller	13
16. Drainback DX Filling and Draining	13
17. Drainback DX Start-Up	13
18. Drainback DX Maintenance	13
19. Operational Checklist	14
Systems Parts List	14

INTRODUCTION

We at AET would like to extend our congratulations on your purchase of an Eagle Sun™ or Sav'n Sun™ DX System. Years of research and development backed by critical engineering have brought you the finest solar products you can buy. Please take time to read this booklet thoroughly. Each step is outlined completely and clarified by diagrams where necessary. All questions which arise

from this material should be answered before you attempt installation of the system. With a little thought and careful planning, your Eagle Sun System can be installed quickly and easily by yourself or by a qualified plumber with a minimum of disruption to your business or home.

“Conservation for today... Energy for tomorrow.”

BASIC TOOLS AND MATERIALS

Electric Drill	Adjustable Wrenches 8" & 10
Drill Index (w/ 1/2" and 3/4" Wood Bits)	Torch and Striker
Hack Saw	100 PSI Pressure Gage
Tubing Cutter	Putty Knife
Tin Snips	High Temperature Pipe Joint Compound
16' Tape Measure	Wire Nuts or Connectors
24" Level	Miscellaneous Copper Pipe & Fittings (3/4")
Flashlight	Solder Flux
Extension Cord	Emory Paper
Slip Joint Pliers	Silicon Caulk and Roof Tar
Needle Nose Pliers	1/2" I.D. and 3/4" I.D. Copper Tubing & Insulation
Pipe Wrenches, 10" & 14"	Angle Iron
Open End Wrenches, 9/16 & 7/16	Threaded Rod, Nuts, & Washers
Screw Driver 6" Flat Blade	Stainless Screw Clamps
Screw Driver 6" Philips	Thermal Adhesive
Wire Stripper or Knife	Aluminum Flashing Sheet
Wire Cutters	

1. COLLECTOR LOCATION

Proper location and orientation of the solar collectors is important for maximum system efficiency. The collectors should be unshaded for the middle six hours of the day in each month of the year and should be located as close to the storage tank as possible to minimize heat loss in the piping runs. The best orientation is achieved

when the collectors are facing due south and tilted at an angle from the horizontal of latitude + 10°. Figure 1 below shows many alternatives for collector mounting. When roof mounting, placing the collectors as close as possible to the peak of the roof will make installation easier due to increased attic access.

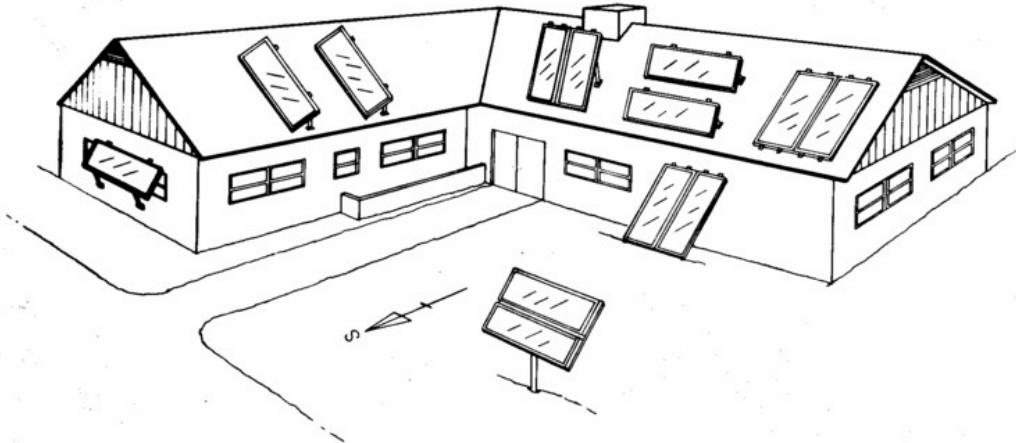

Figure 1

2. COLLECTOR ORIENTATION

Proper tilt angle for solar collectors is latitude plus 10° (see latitude map). This favors the winter sun because ambient temperatures are lower during the winter and collector efficiency suffers. This 10° additional tilt equalizes year round performance. Spacing can be determined from Table 1.

When collectors are mounted one behind the other, they are spaced apart so that in the morning and afternoon on December 21, when the sun is at its lowest altitude, the collectors will not shade each other and cause efficiency loss.

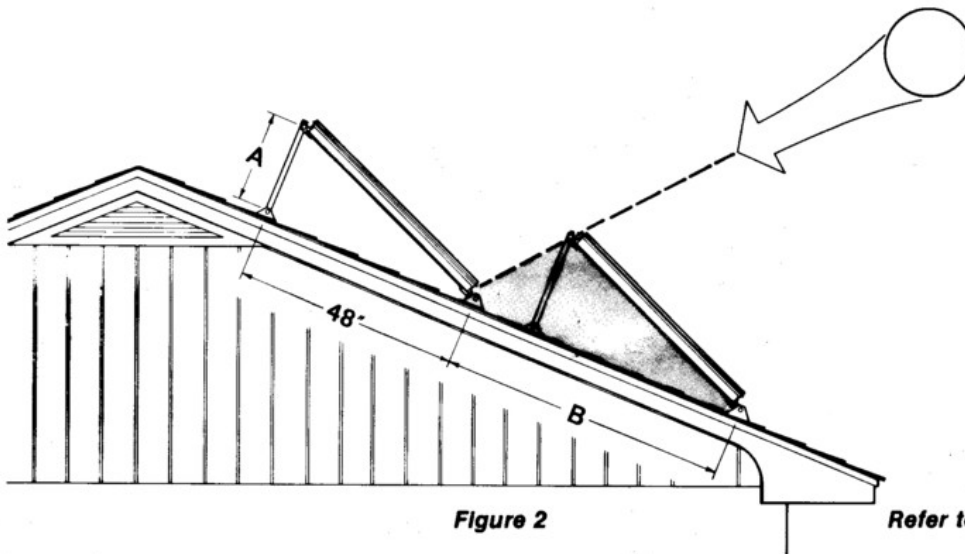

Figure 2

Refer to Table 1

LATITUDE		25° N		30° N		35° N		40° N		45° N		50° N	
COLLECTOR TILT		35°		40°		45°		50°		55°		60°	
		A	B	A	B	A	B	A	B	A	B	A	B
ROOF PITCH	FLAT	29	96	33	113	37	145	41	145	44	145	48	145
	5° 1/12	25	83	29	93	33	113	37	132	41	133	44	141
	9° 2/12	22	74	26	82	30	77	34	110	38	115	41	118
	14° 3/12	17	66	22	72	26	82	30	92	34	95	38	98
	18° 4/12	14	61	18	66	22	74	26	81	30	85	34	87
	23° 5/12	10	58	14	60	18	66	22	72	26	74	30	77
	27° 6/12	7	58	11	58	15	61	19	66	23	68	27	70
	30° 7/12	4	58	8	58	13	58	17	58	21	58	25	58
	34° 8/12	0	58	5	58	9	58	13	58	17	58	22	58
	37° 9/12	-2	58	3	58	7	58	11	58	15	58	19	58
	40° 10/12	-4	58	0	58	4	58	8	58	13	58	17	58
	43° 11/12	-7	58	-3	58	-2	58	6	58	10	58	14	58
	45° 12/12	-8	58	-4	58	0	58	4	58	8	58	13	58
	VERTICAL	-44		-41		-37		-33		-29		-25	

Table 1. All Lengths in inches

3. COLLECTOR DIMENSIONS

Collector	Gross Area (ft ²)	Dimensions (in)	Transparent Area (ft ²)	Weight (lb)
AE-21	20.87	35 3/16 x 85 3/16	19.22	74
AE-24	23.81	35 3/16 x 97 3/16	21.99	84
AE-26	25.35	47 3/16 x 77 3/16	23.65	90
AE-28	27.97	47 3/16 x 85 3/16	26.16	99
AE-32	31.91	47 3/16 x 97 3/16	29.93	113
AE-40	39.79	47 3/16 x 121 3/16	37.47	153
Tested: TUV (DIN 4757, RAPPERSWILL, ONORM M7714, FSEC, SRCC, Metropolitan Dade County, Miami Test Lab				

Table 2. Collector Dimensions for AE series

4. MOUNTING HARDWARE

Provided in the Eagle Sun package is specially designed mounting hardware to speed collector installation. This hardware consists of four LOCK-TIGHT hinge sets, four roof brackets, two rear struts, and bolts (Figures 3, 4, and 5).

- After locating the mounting points from Table 1, the mounting bracket holes should be drilled.
- A heavy coating of sealant should be applied to the bottom of the flashing plate, which should fit flat against the roof. It is necessary for the plate to slide under the above shingles to insure proper drainage of water.
- The bottom of the roof bracket and the area around the threaded rod should also be thoroughly coated with tar sealant. When the bracket is set in place, alignment with the collector hinges is necessary before final tightening of the nuts. This should be completed before the sealant has time to set.
- The threaded rod is fastened through a 2' x 6" wood or 2" x 2" x 1/4" steel angle bracket under the roof as shown.
- The rear struts should be cut and drilled to conform to Table 1. All bolts should be

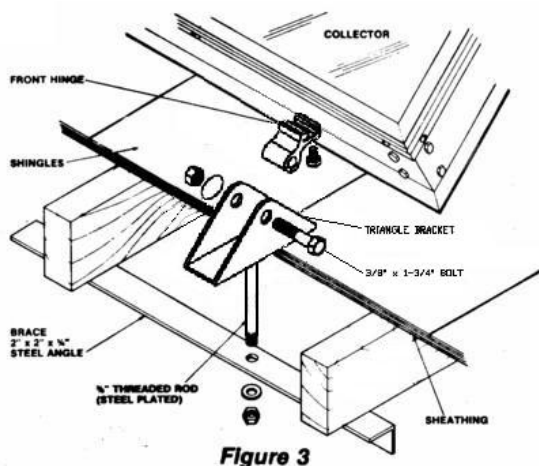

Figure 3

There are three acceptable ways to secure the collector mounting brackets to the roof.

- Spanner Mounting
- Lag Bolt Mounting
- J-Bolt Mounting

In spanner mounting after the brackets are positioned on the chalk line, a 3/8" hole is drilled between the rafters. Aluminum flashing is positioned over the hole where the top of the flashing is extended up under the shingle above the 3/8" hole and extends down over it. Caulk is applied between the flashing and the roof. The bracket is then positioned over

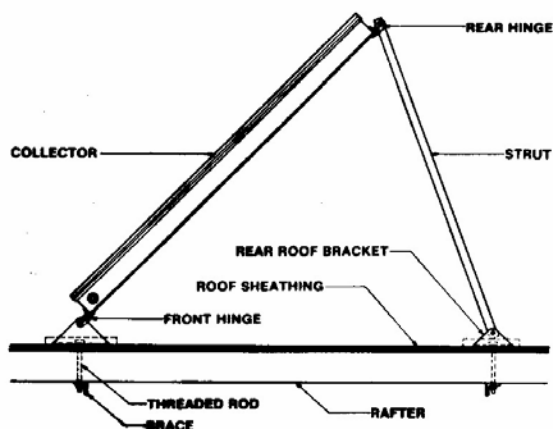

Figure 4

tightened securely. A stainless steel washer should be placed where the threaded rod passes through the aluminum bracket.

It is very important that the penetrations through the roof be well sealed. It should be carefully checked that all bolts are coated with tar and that no leaks are possible.

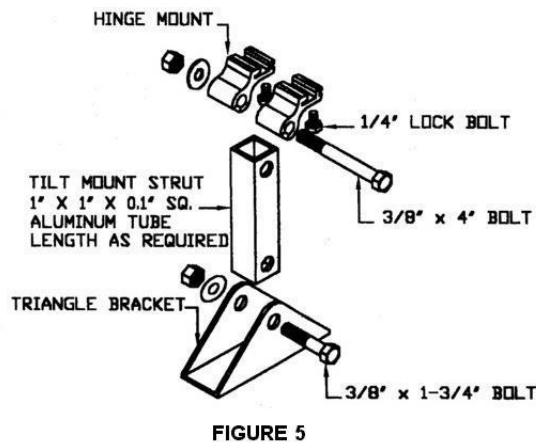

FIGURE 5

the 3/8" hole using sealant between the bracket and the flashing. A piece of 3/8" all-thread is then inserted through the hole. A washer and nut secures the all-thread to the bracket (be sure the seal underneath the washer and on top of the nut). The all-thread rod should extend about 4" below the roof rafters. Drill a 3/8" hole in a 2 x 4 and insert the all-thread rod through it. The 2 x 4 should span 2 rafters. With a washer and double bolt secure the all-thread to the 2 x 4. Tighten down until the bracket is tightly secured to the roof. Be careful not to over-tighten and bell out the roof underneath the bracket. (See Figure 6)

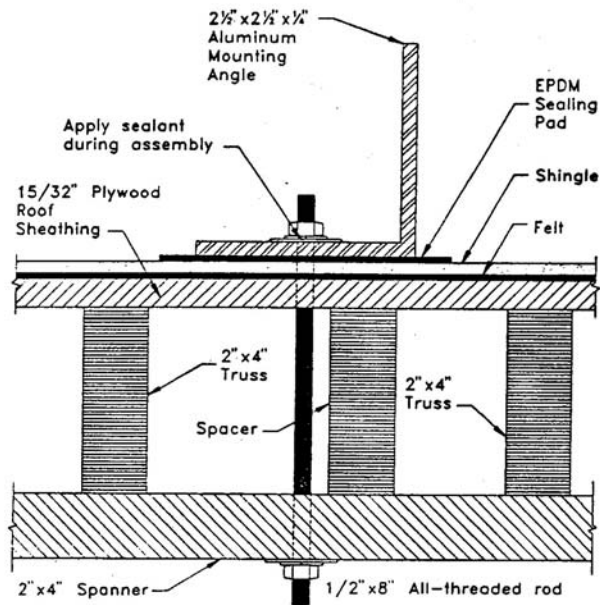

Figure 6. Spanner Mounting

In lag bolt mounting you must locate the center of the rafters along the top and bottom chalk lines. One method is to have one man on the roof and another in the attic. Using a hammer the man on the roof can tap the roof and determine where it is denser sounding. The roof man can drill a pilot hole while the attic man helps with distance corrections.

Then the attic man can call off the distance to the next rafter while the roof man drills corresponding pilot holes. Flashing the brackets is done as previously described. Secure the brackets to the roof using a 1/4" x 3" stainless lag screw, a flat washer, and a lock washer (Figure 7).

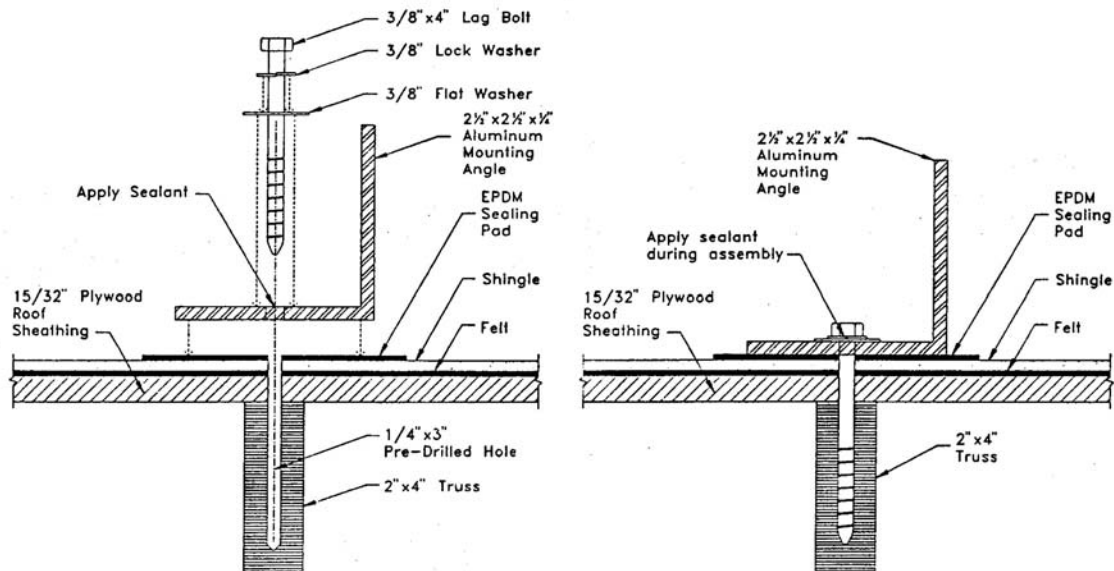

Figure 7. Lag Bolt Mounting

J-bolt mounting is done very similar to lag screw mounting except instead of drilling into the center of a rafter, a hole must be drilled directly beside a rafter. The size of the hole must be slightly larger than the bolt diameter. This is more easily accomplished if the attic man would drill a pilot hole through the roof along side the chosen rafter.

Fit the bolt through the mounting brackets and insert the bolt (J side first) through the hole in the roof. Work the J underneath the rafter. Pull the J-bolt snug against the rafter before tightening the nut. Use double nuts or lock-washers to securely fasten the mounting bracket to the J-bolt (Figure 8).

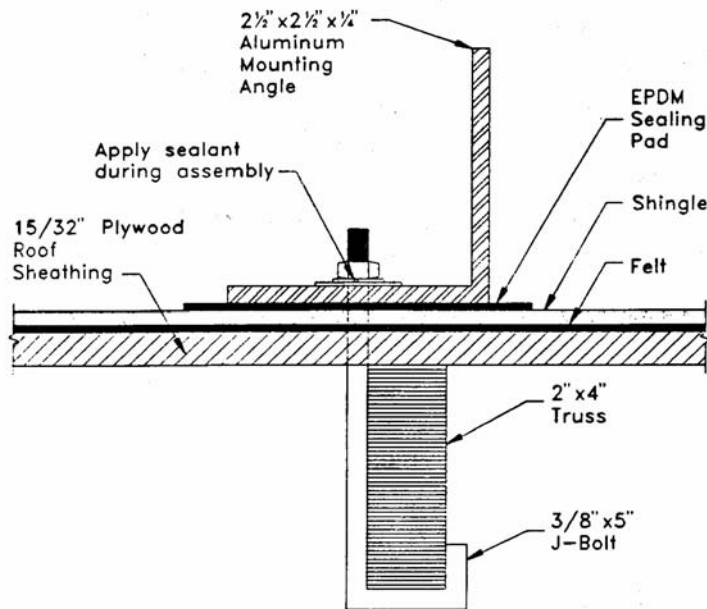

Figure 8. J-Bolt Mounting

5. MOUNTING HARDWARE SPACING

AE-Series			Center Line to Center Line (in.)		
Model	Size (ft)	Outside Box Dim. (in.)	AE-MH	AE-FM	AE-RM
AE-21	3 x 7	35.1875 x 85.1875	88.4375	88.9375	86.9375
AE-24	3 x 8	35.1875 x 97.1875	100.4375	100.9375	98.9375
AE-26	4 x 6.5	47.1875 x 77.1875	80.4375	80.9375	78.9375
AE-28	4 x 7	47.1875 x 85.1875	88.4375	88.9375	86.9375
AE-32	4 x 8	47.1875 x 97.1875	100.4375	100.9375	98.9375
AE-40	4 x 10	47.1875 x 121.1875	124.4375	124.9375	122.9375
MSC-Series			Center Line to Center Line (in.)		
Model	Size (ft)	Outside Box Dim. (in.)	MSC-MH	MSC-FRM	MSC-FM
MSC-21	3 x 7	35.8750 x 86.1250	90.5	87.375	37.125
MSC-24	3 x 8	35.8750 x 98.1250	102.5	99.375	37.125

MSC-26	4 x 6.5	47.8750 x 78.1250	82.5	79.375	49.125
MSC-28	4 x 7	47.8750 x 86.1250	90.5	87.375	49.125
MSC-32	4 x 8	47.8750 x 98.1250	102.5	99.375	49.125
MSC-40	4 x 10	47.8750 x 122.1250	126.5	123.375	49.125

Table 3. Distance between centerlines of top and bottom mounts for all AE and MSC series

6. PITCH PAN

The pitch pan is necessary any time standing water is encountered (Figure 9). The purpose is to provide an adequate seal around any penetration in the roof.

- (a) The pitch pan is placed in the proper position and flat on the roof.
- (b) Its flange is sealed with roofing felt and hot tar.
- (c) The holes are sealed on the inside with roofing tar to a sufficient level to insure a permanent seal.

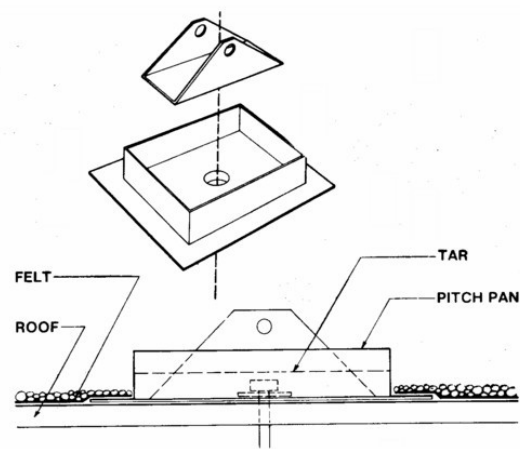

Figure 9

7. ARRAY MOUNTING

Tile roofs are a little more difficult to mount solar collectors on but following this procedure will render a leak free installation.

The solar panels are mounted on two rails located at the top and bottom of the solar collectors. The collectors are secured to the rails using the AE rack mount hardware (AE-RM). The 1 5/8" Aluminum unistrut rails are anchored to the roof by using six or ten inch stainless steel 3/8" hanger bolts. These bolts are lag screw on the bottom and 3/8 NPT thread on the top. A ten foot length of unistrut should be anchored at three points, the middle and both ends.

Procedure

- Cut 12" x 12" square pieces of lead flashing.
- Locate the roof rafters beneath the tile where the hanger bolts will be attached. Drill a 3/8" hole through the tile.
- Slide the 12" x 12" lead flashing under the tile located above the 3/8" hole, then drill through the lead flashing into the hole.

- Screw lag portion of the 3/8" hanger bolt into the rafter.
- Cut strips of the lead flashing about 1 1/2" long and wide enough that when you fold it into a tube is slightly larger in diameter as the hanger bolt.
- Using an acid core solder, weld the seam of the tube together.
- Slip this tube over the top of the hanger bolt protruding from the roof, then solder it to the 12" x 12" lead flashing.
- Thread down a stainless 3/8" nut to the bottom of the thread and seal the top of lead tube to the nut with a polybutylene caulk. Slip a 3/8" stainless washer on top of the nut.
- Place the 1 5/8" aluminum unistrut rail on the hanger bolt and secure with another 3/8" stainless washer and nut.

The rail is now secured, weather tight to the tile roof. Next, mount the AET solar collector to the rail using the AE rack mounts (AE-RM). See Figure 10.

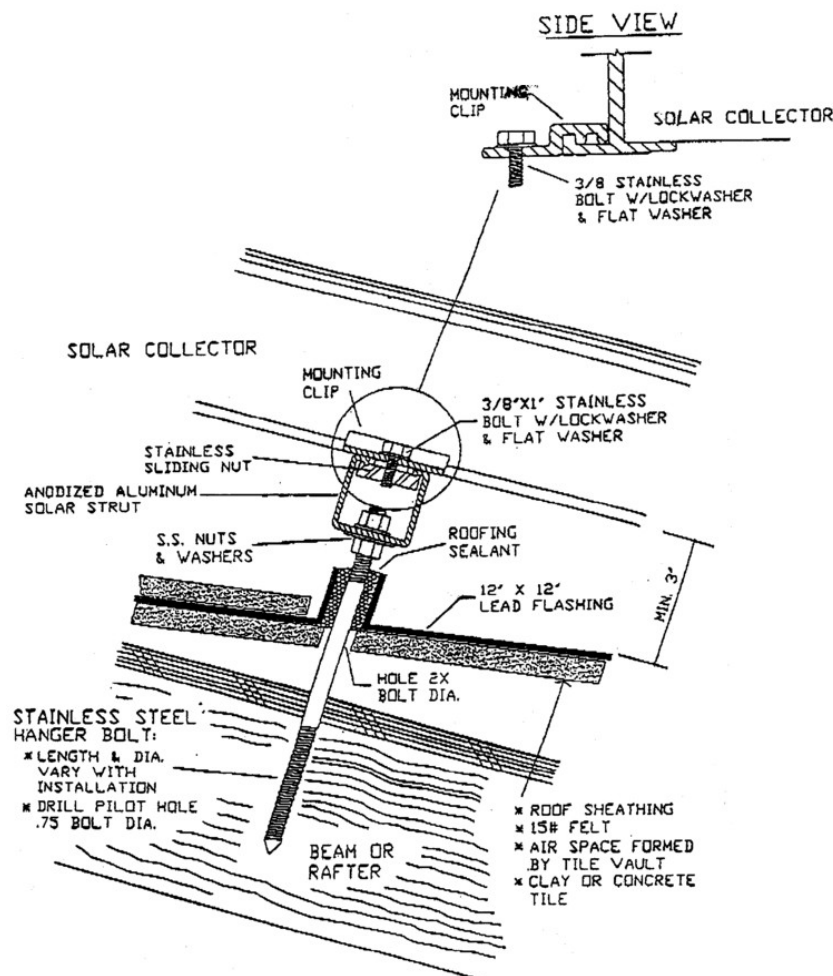

Figure 10

8. COLLECTOR PIPING

All collectors and piping must be sloped a minimum of $\frac{1}{4}$ " per foot for drainage. All piping must drain without any fluid "traps." Soldered connections should be made with 95/5 solder.

The piping of the system should be considered before a final decision is made on how the collectors are mounted. Piping should be made of not less than $\frac{3}{4}$ " I.D. copper tube of the type meeting local codes, insulated with Armaflex or similar, and painted or wrapped with aluminum tape where exposed to ultraviolet radiation.

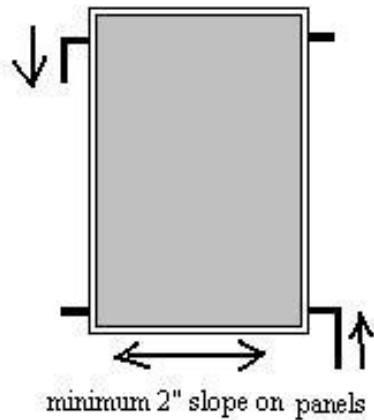

Figure 11

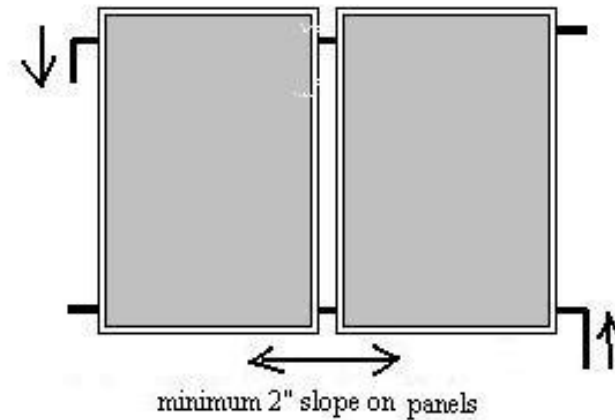

Figure 12

9. COLLECTOR PIPING DETAIL

The outlets of the collector are $\frac{3}{4}$ " copper nipples (Figure 13). They should be piped as shown.

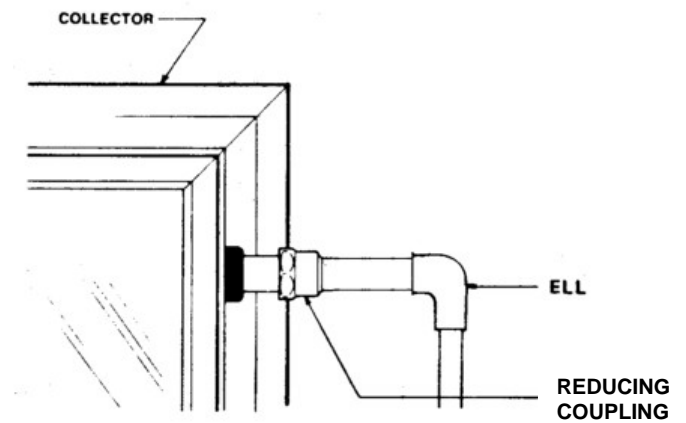

Figure 13

10. SENSOR MOUNTING AT COLLECTOR

The controller heat sensor is mounted to the nipple outlet of the collector (Figures 14). A stainless steel screw clamp should be used. The entire nipple should be wrapped thoroughly with insulating tape so that the sensor is isolated from the outside air.



Figure 14

11. PIPING THROUGH THE ROOF

Piping through the roof should be weatherproofed as shown in Figure 15.

- (a) One inch holes are drilled through the roof on the same plane as the supply and return header nipples. Do not drill the hole above the supply header of the collector. This will prevent the collector from draining. Placing the hole below the supply header is acceptable, but it is more aesthetic if it is located on the same plane
- (b) A copper flashing is placed around the hole with its base cemented to the roof and its upper edges slid under the adjoining shingle.
- (c) The copper tube supply and return line is then pushed up through the hole in the flashing.
- (d) A “coolie cap” is then slid over the copper tube till it meets the flashing. After piping to the collectors is completed, the “coolie cap” is soldered to the copper tube.
- (e) Polybutalyne adhesive is then placed on the top and bottom of the flashing, providing a weatherproof seal. The sensor wire should also be run through the return flashing.

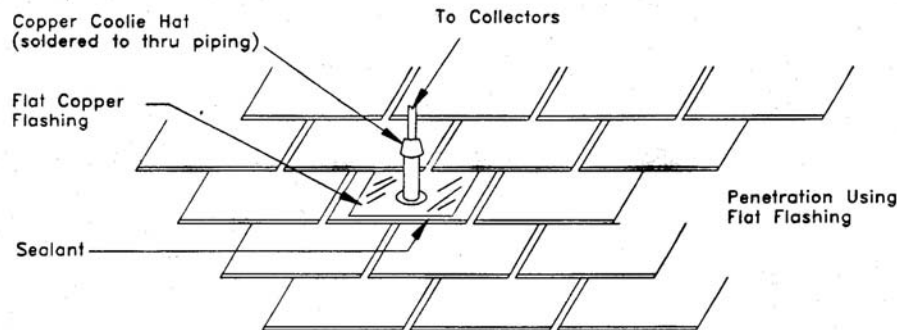

Figure 15

12. STORAGE TANK PLACEMENT

To minimize expense and heat loss, the tank should be placed near the collectors and central to points of greatest water demand. It should be located in as warm a spot as possible. It should be located with adequate ventilation, with a minimum of 6-8 inches of clearance and with ready access to controls and serviceable parts.

Provision should be made to prevent water damage in case of leakage. A catch pan with a minimum of $\frac{3}{4}$ " drain line at least 2" in height may be installed and pitched for proper drainage. Electrical service of 240V should be available for the element and 110V for the pump and controller.

13. SENSOR MOUNTING AT STORAGE TANK

On the American Appliance open loop tanks the heat sensor is located behind the bottom front cover

Procedure:

- 1.) Remove the two screws that secure the bottom cover to the tank.
- 2.) Remove the fiberglass insulation until the shell of the tank is visible.
- 3.) Locate the ¼" threaded stud and nut and the two sensor wires that were factory run from the top of the tank.
- 4.) Remove the ¼" nut from the stud and place the 10 K sensors on the stud. Secure it with the nut.
- 5.) Attach the wires on the sensor to the factory run wires. Note: it does not matter which wire is attached to the other.
- 6.) Replace the insulation and bottom cover.

14. DRAINBACK FLUID HANDLING SYSTEM

The drainback system is a non-pressurized closed loop system. There are two variations available, the "Eagle Sun™" and the "Sav'n Sun™" DX. The "Eagle Sun™" system utilizes a closed loop Rheem tank with a wrap-around heat exchanger. The "Sav'n Sun™" DX system utilizes an open loop solar storage tank with a heat exchanger inside the drainback reservoir.

The "Sav'n Sun™" DX Drainback System (Figure 16)

This system is comprised to the following components:

- Two pumps (CP-009F and CP-003) and flange (Optional: Substitute CP-009F with CP-008F)
- One storage tank (OST-80TCE)
- One differential controller (DTC-GL30)
- One drainback reservoir with heat exchanger (DB-10-10X)

Two fill valves (½" boiler drains) are installed on the inlet to the heat exchanger and one on the top of the drainback reservoir. A hose is attached to the drain valve on the inlet to the heat exchanger. The other drain valve located at the top of the reservoir is opened to allow air to escape. The system is then filled with water through the inlet to the heat exchanger. This way water first fills the heat exchanger then fills the drainback reservoir. You

want to fill the reservoir unit the water level reaches the top of the site glass. At this point both drain valves are closed and the water is shut off. It is important that the system be filled in this manner to prevent the heat exchanger from becoming air locked.

When the differential control turns the pump on, water is pulled from the reservoir and circulated up through the solar collectors and back. This circulated water heats the heat exchanger, which in turn heats the water in the solar storage tank. When the pump shuts off, all the water in the solar collectors is drained back into the reservoir.

It is important to slope the lines going to and coming back from the collectors so water is able to drain. It is recommended to maintain a ¼" slope per foot. The pipe should never run uphill. Some installations may require a horizontal run of these pipes. In these situations a gallon of propylene glycol can be added to the reservoir. If the drainback reservoir is located in an unconditioned space that experiences hard freeze, once again, a gallon of propylene glycol can be added.

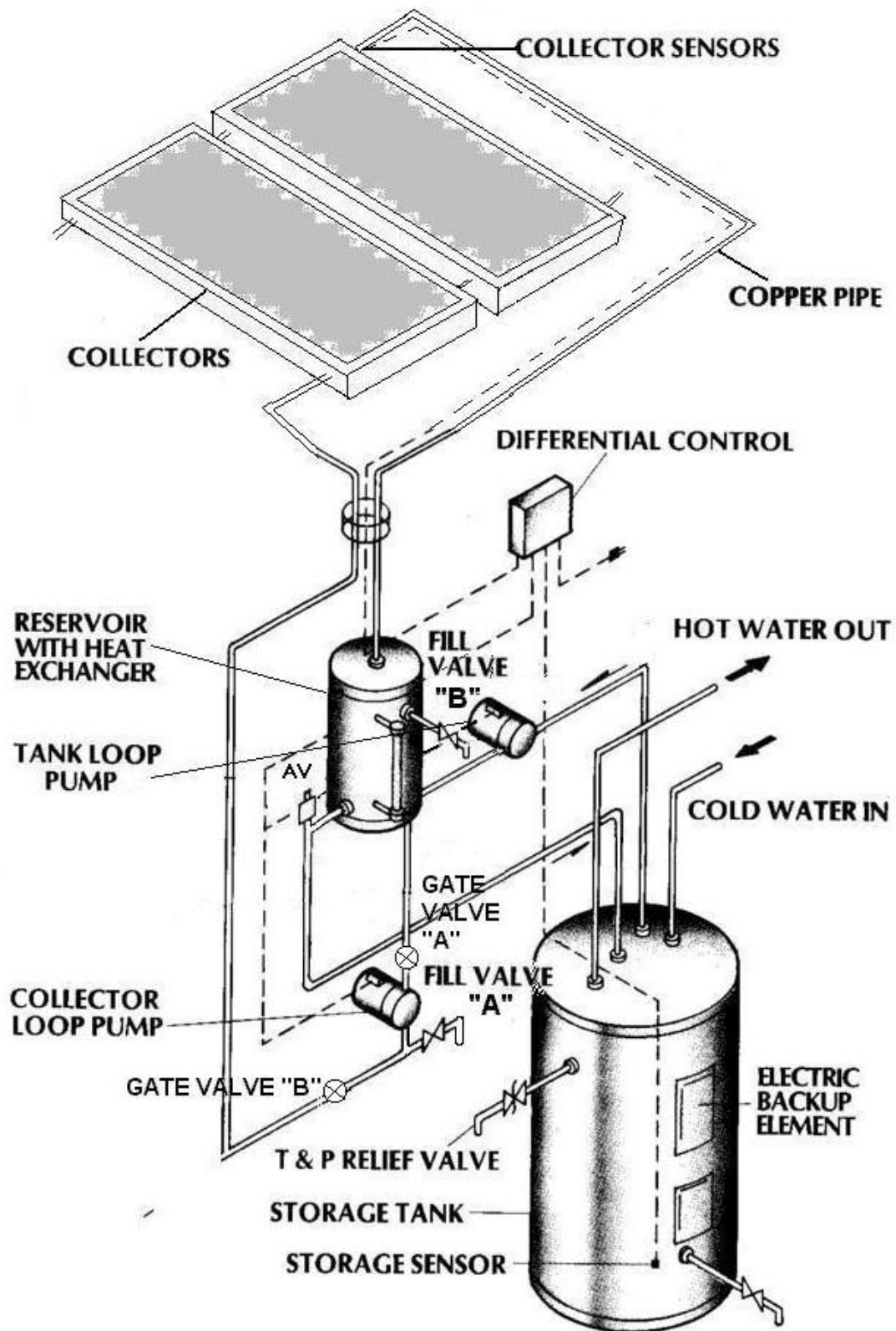

Figure 16. Drainback System with DX Reservoir.

15. DRAINBACK DIFFERENTIAL TEMPERATURE CONTROLLER

See instructions provided with controller in box.

ALL CONNECTIONS SHOULD BE MADE IN ACCORDANCE WITH LOCAL ELECTRICAL CODES!

Specifications:

OPERATING VOLTAGE

105 to 125 vac, 60 Hertz

CONTROL RELAY CONTACT RATING

One third HP inductive load.

TURN-ON DIFFERENTIAL

10⁰F (+1⁰F) for Storage Sensor at 135⁰F

TURN-OFF DIFFERENTIAL

5⁰F (+1⁰F) for Storage Sensor at 135⁰F

SENSOR MATCHING ACCURACY

1⁰F or less at 135⁰F

MAXIMUM SENSOR TEMPERATURE

300⁰F

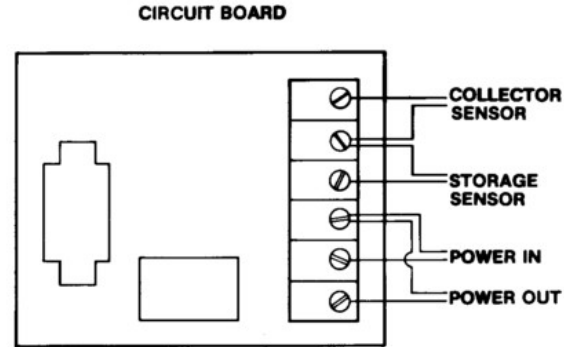

Figure 17

16. FILLING AND DRAINING THE DX RESERVOIR

Filling the "Sav'n SunTM" DX Reservoir:

- 1.) Open fill valves "A" and "B"
- 2.) Open gate valve "A" and close gate valve "B"
- 3.) Attach hose to fill valve "A"
- 4.) Fill reservoir to the top of the site glass
- 5.) Shut off fill valves "A" and "B"
- 6.) Remove fill hose
- 7.) Open gate valve "B"

Draining the "Sav'n SunTM" DX Reservoir

- 1.) Shut off controller and wait until all water is back in reservoir
- 2.) Attach hose to fill valve "A"
- 3.) Open fill valve "B"
- 4.) Open fill valve "A" (fill valve "B" MUST be open first)

When filling the potable water side of the DX system be sure to open the hot water faucet in the bath tub to release the air from the system.

17. DRAINBACK DX START-UP

After installation and final inspection, the system should be filled and checked for leaks for ½ hour. (see Figure 20). To charge the system:

- a) Connect hose to fill valve A.
- b) Open fill valves A and B.
- c) SLOWLY Fill the system with water until water reaches to the top of the site glass.
- d) Close fill valves A & B.

- e) Turn on pump and let run for 5 minutes
- f) Check for leaks at collectors and in attic.
- g) Switch controller to automatic mode.

If the sun is shining and the tank is cool, the pump should turn on and the water should circulate. The return lines from the collectors should be hotter than the inlet lines and the collector glass should be slightly warmer than ambient temperature.

18. DRAINBACK DX MAINTENANCE

Maintenance of a drainback system is minimal. The storage tank should be partially drained every 6 months to allow minerals to be removed preventing scale build up (this is recommended for all water heaters).

The collector glass should be kept clean for best system performance. Rain water will usually suffice, but a garden hose can be used during dry, dusty weather.

19. OPERATIONAL CHECKLIST

Before the system is turned on, the piping and electrical systems should be evaluated to see if they match the supplied drawings. If you are satisfied that the system is installed correctly, it should be filled and powered according to the preceding instructions. When the system is in the operational mode, care should be taken to check all piping for leaks and to make sure sufficient insulation has been used to provide maximum system efficiency. All modes of operation should be checked by the installer to assure proper functioning under all conditions.

TROUBLE SHOOTING GUIDE

Problems with systems usually fall under two categories: system leaks or lack of sufficient solar heated water.

LEAKS

If leaks exist the system should be shut down for repairs. Make sure the electrical circuit to the controller is off. Close off the cold water inlet or in case of a leak in the closed loop system, isolate as much of the system as possible and then drain and repair the affected area.

There is a possibility that what appears to be leaks may be condensation on the pipes. Also water escaping for the T & P valve may be an indication of proper function as they are designed to vent off excess temperature and pressure.

INSUFFICIENT HOT WATER

If insufficient hot water is available a system malfunction may not be indicated. A low amount of solar radiation or heavy water demand can be the cause.

SYSTEM PARTS LIST

Solar Collectors
 Set of Mounting Hardware for each collector
 Hot Water Storage Tank
 High-head Pump
 Pump Flanges
 Low-head Pump (on DX Systems only)
 Differential Temperature Controller
 Controller Sensors
 Drainback Reservoir
 Installation Manual

If no excessive demands are put on the system and ample solar radiation is available, the system should operate properly. The pump should run each sunny day until a full supply of hot water is stored. If the pump does not run, there is a problem on the electrical end of the system. Either the pump, controller, or sensors are malfunctioning. The controller can be bypassed by running a power cable directly to the pump and checking its function separate from the control system. Make sure that the problem is not a blown fuse or a tripped breaker. If the pump runs normally when powered externally, the control circuit is the problem area. Eagle Sun controllers use thermistor sensors to determine modes of operation. A controller tester is available from AET for checking differential function. Check sensor wiring. If no faulty wiring can be discovered, replace sensors.

If the pump is running all the time, even when the collectors are cool, then the storage sensor or collector sensor may be open. It is also possible that the sensor wire itself is at fault. To check this, test the continuity with an ohm meter. Be sure to disconnect the sensor when performing this test. Test the wire with both ends open, then retest often twisting the 2 sensor wires together at one end. The system can be set on a timer or switched on manually until the controller is properly functioning.

OTHER PROBLEMS

A noisy pump is an indication of worn bearings obstruction or loss of prime. As a rule of thumb about 8 to 12 degrees should be expected as a normal gain across a collector in bright sun at proper flow rate.