

USER'S INFORMATION MANUAL

UPFLOW TWO-STAGE CONDENSING GAS FURNACES

SAFETY



Recognize this symbol as an indication of Important Safety Information!

▲ WARNING

PROPOSITION 65 WARNING: THIS PRODUCT CONTAINS CHEMICALS KNOWN TO THE STATE OF CALIFORNIA TO CAUSE CANCER, BIRTH DEFECTS OR OTHER REPRODUCTIVE HARM.

▲ WARNING

If the information in this manual is not followed exactly, a fire or explosion may result, causing property damage, personal injury or loss of life.

▲ WARNING

FIRE OR EXPLOSION HAZARD

Failure to follow safety warnings exactly could result in serious injury, death or property damage.

- Do not store or use gasoline or other flammable vapors and liquids in the vicinity of this or any other appliance.
- WHAT TO DO IF YOU SMELL GAS
 - Do not try to light any appliance.
 - Do not touch any electrical switch; do not use any phone in your building.
 - Leave the building immediately.
 - Immediately call your gas supplier from a neighbor's phone. Follow the gas supplier's instructions.
 - If you cannot reach your gas supplier, call the fire department.
- INSTALLATION AND SERVICE MUST BE PERFORMED BY A QUALIFIED INSTALLER, SERVICE AGENCY OR THE GAS SUPPLIER.

IMPORTANT: READ THESE INSTRUCTIONS THOROUGHLY BEFORE ATTEMPTING TO OPERATE THIS FURNACE.

This furnace has been designed to give you many years of efficient, dependable home comfort. With regular maintenance, this furnace will operate satisfactorily year after year. Please read this manual to familiarize yourself with operation, routine maintenance schedule, and safety procedures.

▲ WARNING

DEVICES ATTACHED TO THE FLUE OR VENT FOR THE PURPOSE OF REDUCING HEAT LOSS UP THE CHIMNEY, INCLUDING FIELD-INSTALLED DRAFT INDUCERS, HAVE NOT BEEN TESTED AND HAVE NOT BEEN INCLUDED IN THE DESIGN CERTIFICATION OF THIS FURNACE. WE, THE MANUFACTURER, CANNOT AND WILL NOT BE RESPONSIBLE FOR INJURY OR DAMAGE CAUSED BY THE USE OF SUCH UNTESTED AND/OR UNCERTIFIED DEVICES, ACCESSORIES OR COMPONENTS.

▲ WARNING

IMPROPER INSTALLATION, ADJUSTMENT, ALTERATION, SERVICE OR MAINTENANCE CAN CAUSE PROPERTY DAMAGE, PERSONAL INJURY OR DEATH. FOR ASSISTANCE OR ADDITIONAL INFORMATION CONSULT A QUALIFIED INSTALLER, SERVICE AGENCY OR THE GAS SUPPLIER.

▲ WARNING

OBSTRUCTION OF THE AIR VENT ON AN LP (PROPANE) TANK REGULATOR CAN CAUSE EXPLOSION OR FIRE RESULTING IN PROPERTY DAMAGE, SEVERE PERSONAL INJURY OR DEATH. YOUR GAS SUPPLIER SHOULD PERIODICALLY INSPECT AND

CLEAN THE AIR VENT SCREEN TO PREVENT ANY OBSTRUCTION. KEEP PROTECTIVE REGULATOR COVER IN PLACE, AS EXPOSURE TO THE ELEMENTS CAN CAUSE ICE BUILDUP AND REGULATOR FAILURE.

▲ WARNING

DO NOT USE THIS FURNACE IF ANY PART HAS BEEN UNDER WATER. A FLOOD-DAMAGED FURNACE IS EXTREMELY DANGEROUS. ATTEMPTS TO USE THE FURNACE CAN RESULT IN FIRE OR EXPLOSION. A QUALIFIED SERVICE AGENCY SHOULD BE CONTACTED TO INSPECT THE FURNACE AND TO REPLACE ALL GAS CONTROLS, CONTROL SYSTEM PARTS, ELECTRICAL PARTS THAT HAVE BEEN WET OR THE FURNACE IF DEEMED NECESSARY.

CAREFULLY FOLLOW THESE SAFETY RULES:

1. Combustible material must not be placed on or against the furnace jacket. The area around the furnace must be kept clear and free of all combustible materials including gasoline and other flammable vapors and liquids.
2. A furnace installed in an attic or other insulated space must be kept free and clear of insulating material. Examine the furnace area when installing the furnace or adding more insulation. Some materials may be combustible.
3. To prevent carbon monoxide poisoning, all blower doors and compartment covers must be replaced after the furnace is serviced. Do not operate the unit without all panels and doors securely in place.
4. Should overheating occur, or the gas valve fail to shut off the gas supply, turn off the manual gas

DO NOT DESTROY. PLEASE READ CAREFULLY AND KEEP IN A SAFE PLACE FOR FUTURE REFERENCE.

valve to the furnace before turning off the electrical supply.

- Any additions, changes or conversions required in order for the furnace to satisfactorily meet the application should be made by a qualified installer, service agency or the gas supplier, using factory specified or approved parts. Read your WARRANTY. This furnace was equipped at the factory for use on NATURAL GAS ONLY. Conversion to L.P. GAS requires a special kit supplied by the equipment manufacturer.

- A furnace needs an adequate supply of combustion and ventilation air for proper and safe operation. Do not block, enclose or obstruct air openings on the furnace or air openings supplying the area where the furnace is installed. Do not store anything around the furnace that could block the flow of fresh air to the unit. Your installation may receive air from the inside heated space, from the outside, from the attic or crawl space. Whenever adding insulation, be sure the air supply openings are not covered.

▲ WARNING

DO NOT USE THIS FURNACE IF ANY PART HAS BEEN UNDER WATER. A FLOOD-DAMAGED FURNACE IS EXTREMELY DANGEROUS. ATTEMPTS TO USE THE FURNACE CAN RESULT IN FIRE OR EXPLOSION. A QUALIFIED SERVICE AGENCY SHOULD BE CONTACTED TO INSPECT THE FURNACE AND TO REPLACE ALL GAS CONTROLS, CONTROL SYSTEM PARTS, ELECTRICAL PARTS THAT HAVE BEEN WET OR THE FURNACE IF DEEMED NECESSARY.

SYSTEM OPERATION INFORMATION

- Keep the air filters clean. Your heating system will operate more efficiently and provide better heating, more economically.
- Arrange your furniture and drapes so that the supply air registers and the return air grilles are unobstructed.
- Close doors and windows. This will reduce the heating load on your system.
- Avoid excessive use of exhaust fans.
- Do not permit the heat generated by appliances such as televisions, lamps, or radios to influence the thermostat operation.
- If you desire to operate your system with constant air circulation, consult your thermostat manual or obtain advice from a qualified installer, service agency or the gas supplier.

During the heating season the operation of the warm air furnace is automatic. Your qualified installer, service agency or the gas supplier has provided a wall mounted thermostat which is sensitive to the change in temperature of the air moving around the thermostat. Your thermostat will have switches to select some or all of the following functions:

HEAT - Turns heating on when temperature drops below the desired temperature.

COOL - Turns cooling on when temperature rises above the desired temperature.

FIGURE 1
BURNER COMPARTMENT - SHOWING LOCATION OF GAS CONTROLS

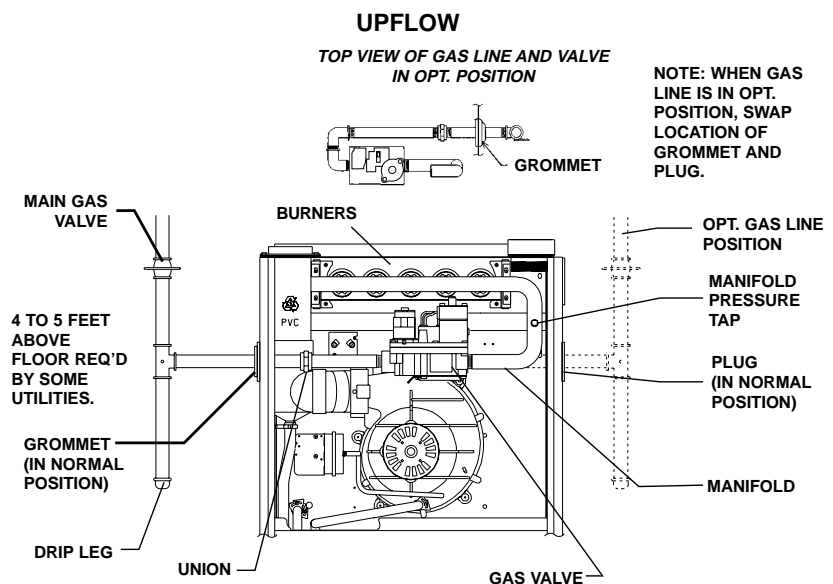

IMPORTANT: DO NOT RUN A FLEXIBLE GAS CONNECTOR INSIDE THE UNIT. Extend the 1/2" black pipe from the gas valve to the union outside of the cabinet. Connect any flexible gas connector from there to the gas piping.

AUTO - Turns cooling or heating system on as required to maintain the desired temperature.

OFF - Turns heating and cooling modes off. (The blower may still circulate air in the FAN-ON position.)

FAN-ON - Turns the blower on for continuous operation.

FAN-AUTO - The blower cycles on and off with cooling or heating operation.

FIGURE 2
TYPICAL DIRECT SPARK IGNITION GAS VALVE

Manual gas control switch shown in "ON" position.

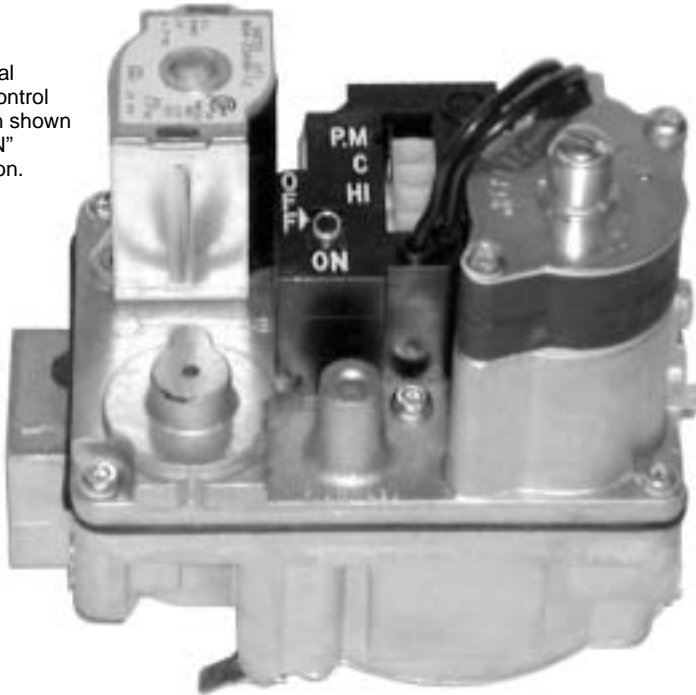

FOR YOUR SAFETY READ BEFORE OPERATING

▲ WARNING

IF YOU DO NOT FOLLOW THESE INSTRUCTIONS EXACTLY, A FIRE OR EXPLOSION MAY RESULT CAUSING PROPERTY DAMAGE, PERSONAL INJURY OR LOSS OF LIFE.

NOTE: Read and follow the Safety Information, Operating Instructions and Instructions To Turn Off Gas To Appliance located on the furnace. This label will have specific information regarding the furnace and its gas controls.

LIGHTING INSTRUCTIONS

DIRECT SPARK IGNITION

This appliance is equipped with a direct spark ignition device. This device lights the main burners each time the room thermostat (closes) calls for heat. See lighting instructions on the furnace.

▲ WARNING

TO START FURNACE

1. BE SURE THAT THE MANUAL GAS CONTROL HAS BEEN IN THE "OFF" POSITION FOR AT LEAST FIVE MINUTES. DO NOT ATTEMPT TO MANUALLY LIGHT THE MAIN BURNERS. FAILURE TO FOLLOW THIS WARNING CAN CAUSE A FIRE OR AN EXPLOSION RESULTING IN PROPERTY DAMAGE, PERSONAL INJURY OR DEATH.
2. Set the room thermostat to the lowest setting.
3. Turn the gas control knob to the "On" position, or set the gas control switch to the "On" position.
4. Replace the control access door.
5. Turn on the electrical power.
6. Set the room thermostat to "Heat" one point above room temperature to light the main burners. After the burners are lit, set room thermostat to a desired temperature.

TO SHUT DOWN FURNACE

1. Set the room thermostat to its lowest setting. Turn the thermostat to "Off."
2. Shut off the gas to main burners by turning the gas control switch to the "Off" position, or by setting the gas control switch to the "Off" position.

▲ WARNING

SHOULD OVERHEATING OCCUR OR THE GAS SUPPLY FAIL TO SHUT OFF, SHUT OFF THE MANUAL GAS VALVE TO THE APPLIANCE BEFORE SHUTTING OFF THE ELECTRICAL SUPPLY. FAILURE TO DO SO CAN CAUSE AN EXPLOSION OR FIRE RESULTING IN PROPERTY DAMAGE, PERSONAL INJURY OR DEATH.

MAINTENANCE

⚠ WARNING

DISCONNECT MAIN ELECTRICAL POWER TO THE UNIT BEFORE ATTEMPTING ANY MAINTENANCE. FAILURE TO DO SO CAN CAUSE ELECTRICAL SHOCK RESULTING IN SEVERE PERSONAL INJURY OR DEATH.

⚠ CAUTION

DO NOT OPERATE YOUR SYSTEM FOR EXTENDED PERIODS WITHOUT FILTERS. A PORTION OF THE DUST ENTRAINED IN THE AIR MAY TEMPORARILY LODGE IN THE AIR DUCT RUNS AND AT THE SUPPLY REGISTERS. ANY RECIRCULATED DUST PARTICLES WILL BE HEATED AND CHARRED BY CONTACT WITH

THE FURNACE HEAT EXCHANGER. THIS RESIDUE WILL SOIL CEILINGS, WALLS, DRAPES, CARPETS, AND OTHER HOUSEHOLD ARTICLES. IT IS RECOMMENDED THAT AN ANNUAL INSPECTION OF YOUR FURNACE BE DONE BY A QUALIFIED INSTALLER, SERVICE AGENCY OR THE GAS SUPPLIER.

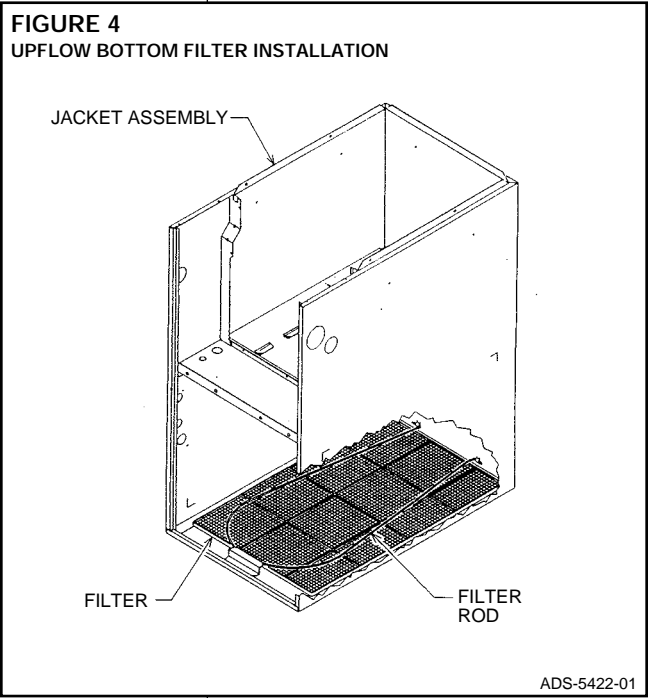
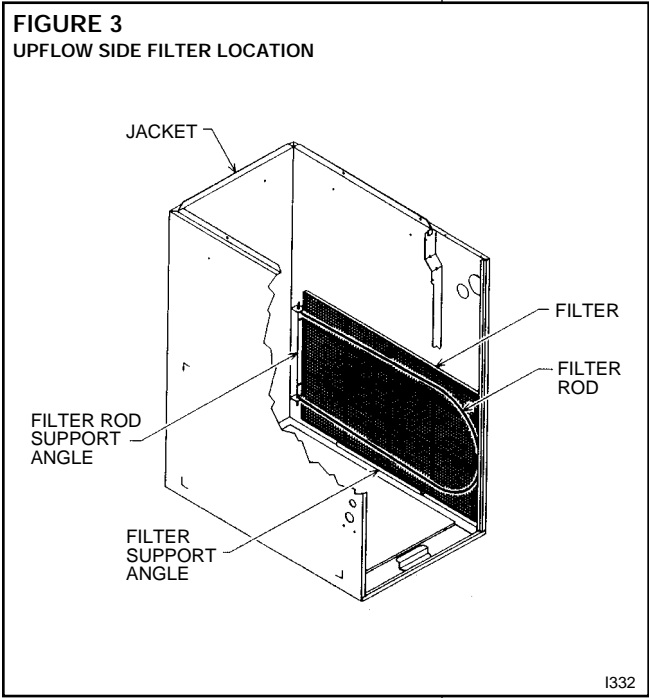

| UPFLOW FILTER SIZES | | | | |
|---------------------|------------------|-------------|------------|----------|
| FURNACE WIDTH | INPUT MBTUH | BOTTOM SIZE | SIDE SIZE | QUANTITY |
| 17½" | 45, 60, 75, 75N, | 15¾" X 25" | 15¾" X 25" | 1 |
| 21" | 75W, 90 AND 105 | 19¾" X 25" | 15¾" X 25" | 1 |
| 24½" | 120 | 22¾" x 25" | 15¾" x 25" | 1 |

FILTER MAINTENANCE

Have your qualified installer, service agency or the gas supplier instruct you on how to access your filters for regular maintenance.

▲ CAUTION

DO NOT OPERATE THE SYSTEM FOR EXTENDED PERIODS WITHOUT FILTERS. A PORTION OF THE DUST ENTRAINED IN THE AIR MAY TEMPORARILY LODGE IN THE AIR DUCT RUNS AND AT THE SUPPLY REGISTERS. ANY RECIRCULATED DUST PARTICLES WILL BE HEATED AND CHARRED BY CONTACT WITH THE FURNACE HEAT EXCHANGER. THIS RESIDUE WILL SOIL CEILINGS, WALLS, DRAPES, CARPETS AND OTHER HOUSEHOLD ARTICLES AND MAY RESULT IN UNPLEASANT ODORS.

▲ WARNING

TURN OFF ELECTRICAL POWER TO FURNACE BEFORE REMOVING FRONT ACCESS DOOR. FAILURE TO DO SO CAN RESULT IN ELECTRICAL SHOCK, SEVERE PERSONAL INJURY OR DEATH.

Keep air filters clean at all times. Vacuum dirt from filter, wash with detergent and water, air dry thoroughly and reinstall.

After filters are cleaned and returned to the furnace, be sure doors are properly reinstalled. If you are not totally sure of this procedure, consult a qualified installer, service agency or the gas supplier.

REMOVING FILTERS

UPFLOW FURNACE - FILTER IN BOTTOM OR SIDE LOCATION

1. Remove the blower compartment access door.
2. Disengage the filter retaining rod and pull filter out.
3. Clean filter and reinstall.
4. Replace the blower compartment access door.

ROUTINE MAINTENANCE

Routine maintenance must be provided by a qualified installer, service agency or the gas supplier ONLY.

LUBRICATION

The blower motor and induced draft motor are prelubricated by the manufacturer and do not require further attention.

IMPORTANT: DO NOT attempt to lubricate the bearings on the blower motor or the induced draft blower motor. Addition of lubricants can reduce the motor life and void the warranty.

▲ WARNING

DISCONNECT MAIN ELECTRICAL POWER TO THE UNIT BEFORE ATTEMPTING ANY MAINTENANCE. FAILURE TO DO SO CAN RESULT IN ELECTRICAL SHOCK, SEVERE PERSONAL INJURY OR DEATH.

The blower compartment and motor should be inspected and cleaned periodically by your qualified installer, service agency or the gas supplier to prevent the possibility of overheating due to an accumulation of dust and dirt on the windings, on the motor exterior, and the air filters. Dirty filters can restrict airflow. The motor depends upon sufficient air flowing across and through it to keep from overheating.

RECOMMENDED ROUTINE MAINTENANCE

1. It is recommended that an annual inspection of your furnace, supply, return and vent system be done by a qualified installer, service agency or the gas supplier.
2. Gas burners should be inspected for dirt, rust, or scale and cleaned as necessary.

▲ WARNING

IF DIRT, RUST, SOOT OR SCALE ACCUMULATIONS ARE PRESENT, DO NOT OPERATE THE FURNACE. THE HEAT EXCHANGERS SHOULD BE INSPECTED FOR LEAKS. LEAKS CAN CAUSE TOXIC FUMES TO ENTER THE HOME AND CAUSE CARBON MONOXIDE POISONING OR DEATH.

4. Inspect the the flue connection area and vent pipe. Be sure that the vent connector is in place and slopes upward and is physically sound, without holes or excessive corrosion. The inlet combustion air system should also be inspected for soundness and absence of restrictions where applicable

▲ WARNING

CHECK VENT PIPE SECTIONS FOR DETERIORATION AND CHECK JOINT FITTINGS FOR THEIR INTEGRITY. IF IT HAS BECOME DISCONNECTED. TOXIC FUMES CAN ESCAPE INTO THE HOME AND CAUSE CARBON MONOXIDE POISONING OR DEATH. DO NOT OPERATE THIS FURNACE. APPROPRIATE SERVICE MUST BE APPLIED.

5. Be sure that the return air duct connections are physically sound, are sealed to the furnace casing and terminate outside the space containing the furnace.
6. Be sure the physical support of the furnace is sound, without sags, cracks, etc., around the base so as to provide a seal between the support and the base.
7. Look for obvious signs of deterioration of the furnace. Check the drain system.
8. If the furnace is free of the above conditions, replace the access doors and restore electrical power to the furnace.
9. Start the furnace and observe its operation. Watch the burner flames to see if they are bright blue. If a suspected malfunction is observed, or the burner flames are not bright blue, apply appropriate service.

CONDENSATE

NOTE: This furnace is equipped with a pressure switch which will shut off the main burners if the condensate drain line becomes blocked.

Be sure this condensate drain line does not become blocked or plugged. Visual inspection of condensate flow can easily be made while the furnace is in operation. A flashlight can be used to illuminate the discharge end.

Clean and flush the condensate tube to make sure condensate flows freely while the furnace is in operation.

If a means to neutralize the condensate has been provided for the furnace, be sure to follow the maintenance schedule furnished by the manufacturer.

